



**STRONG PARTNERS. TOUGH TRUCKS.™**

## **Economy Line Hand Pallet Truck ELPM 2.5**



# Hand Pallet Truck dimensions

Characteristics	1.1	<b>Manufacturer</b>	
	1.2	Model designation	
	1.3	Power: battery, diesel, LPG, electric mains	
	1.4	Operation: manual, pedestrian, stand, seat, order picker	
	1.5	Load capacity	Q (kg)
	1.6	Load centre	c (mm)
	1.8	Load distance	x (mm)
	1.9	Wheelbase	y (mm)

<b>Hyster</b>	
ELPM 2.5	
Manual	
Manual / Tiller	
2500	
600	
985	
1240	

2.1	Unladen weight	kg
-----	----------------	----

78
----

Wheels & Tyres	3.1	Tyres: rubber, polyurethane, vulkolan front / rear	
	3.2	Tyre size, front	
	3.3	Tyre size, rear	
	3.5	Wheels, number front/rear	
	3.6	Track width, front	$b_{10}$ (mm)
	3.7	Track width, rear	$b_{11}$ (mm)

PU / Nylon	
Ø 180 x 50	
Ø 74 x 93	Ø 74 x 70
2/2	2/4
170	
440	430

Dimensions	4.4	Lift height	$h_3$ (mm)
	4.9	Height of tiller arm in working position	$h_{14}$ (mm)
	4.15	Height, lowered	$h_{13}$ (mm)
	4.19	Overall length	$l_1$ (mm)
	4.20	Length to face of forks	$l_2$ (mm)
	4.21	Overall width	$b_1/b_2$ (mm)
	4.22	Fork dimensions	s/e/l (mm)
	4.25	Outside fork width	$b_5$ (mm)
	4.32	Ground clearance, centre of wheelbase	$m_2$ (mm)
	4.33	Aisle width with pallets 1000x1200 mm wide	$A_{st}$ (mm)
	4.34	Aisle width with pallets 800x1200 mm wide	$A_{st}$ (mm)
4.35	Turning radius	$W_a$ (mm)	

190		
1 225		
75		
1530		
380		
520	685	
50	160	1150
520	685	
30		
1 548		
1 748		
180		

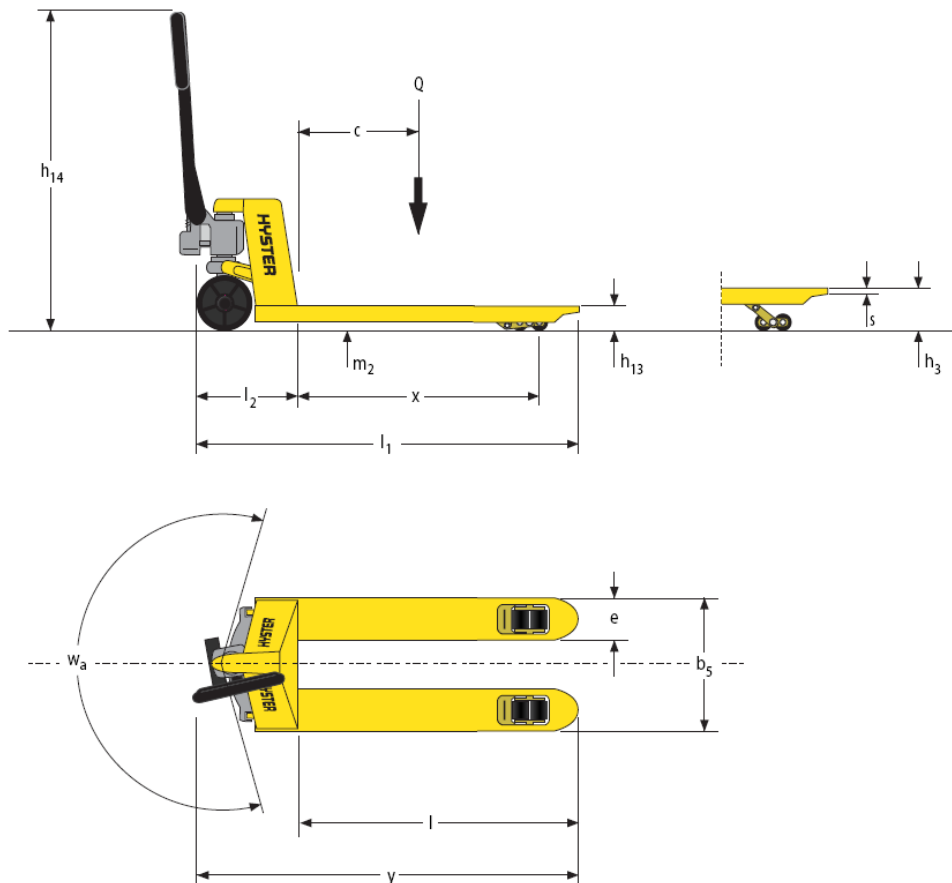



## Product Features

### Frame

- Rugged heavy duty frame constructed of one-piece formed channel steel offering light weight strength.
- Reinforced gussets and bulk head.

### Forks

- Reinforced for added strength.
- Tapered ends for easy pallet entry.

### Paint

- Quality powder coat finish.

### Hydraulic pump

- Quality pump design complete with a special lowering valve allowing controlled rate of descent, and an overload by-pass valve.

### Pump stroke

- Features a full 90 degree top to bottom stroke.
- Requires 10 strokes to raise the forks to the maximum lift.

### Handle

- Features a bolt-on spring-a-matic handle that returns to the upright position automatically.

### Control handle

- The control handle has a three position (raise/neutral/lower) fingertip control.

### Steering

- Featuring 180 degree pivot action, with 180 mm diameter wheels, sealed bearings and "ball-thrust" steering.
- Articulating axle allows for level transport of loads on uneven floors.

### Load rollers

- Features 74 mm polyurethane rollers with sealed bearings.

### Push rods

- The adjustable push rods allow for individual adjustment capability of either fork height.

### Hangers

- The one piece hangers are constructed of iron cast for greater strength and longevity.

### Helper guide

- Features entry and exit ramp for easy handling of pallets.

### Pivot points

- Features grease fittings and bushings at all pivot points for easy maintenance.

### Warranty

- 2-year pump warranty.



### Hyster Europe, Aftermarket Marketing

P.O. Box 136, 6500 AC Nijmegen, the Netherlands

Tel: +31 (0)24 3742433 Fax: +31 (0)24 3742551

[www.hysterdealer.com](http://www.hysterdealer.com)